

## ANKER EAA-Pad®

ACCESSIBLE SERVICE AT SELF-SERVICE TERMINALS

® Registered EU trade mark

### Accessible operation

The EAA-Pad from ANKER makes every self-service terminal terminal barrier-free - whether self-checkouts in the super-market, self-service scales, ticket machines or information terminals. With haptic buttons, audio support and flexible installation options, it enables easy navigation for people with visual impairments or limited motor skills. The EAA-Pad makes it possible self-service terminals to comply with the current legal comply with current legal accessibility requirements.

### Advantages

- **Legal requirements** - BFGS & EAA require barrier-free design of digital systems.
- **Inclusion & participation** - Equal use for people with visual impairments, reading difficulties or limited fine motor skills.
- **Facilitated navigation** - Haptic button control & audio support for barrier-free menu handling.
- **DIN EN 301-549 conformity** - fulfils the standard for accessible ICT.
- **Audio support** - Output digital content via headphones for auditory user guidance.
- **Flexible integration** - Horizontal, vertical, pole mounting & customised brackets.
- **Easy to find** - RGB backlighting facilitates identification.
- **Hardware as enabler** - Supports software solutions for maximum accessibility.
- **Future-proof** - Early implementation protects against future requirements.

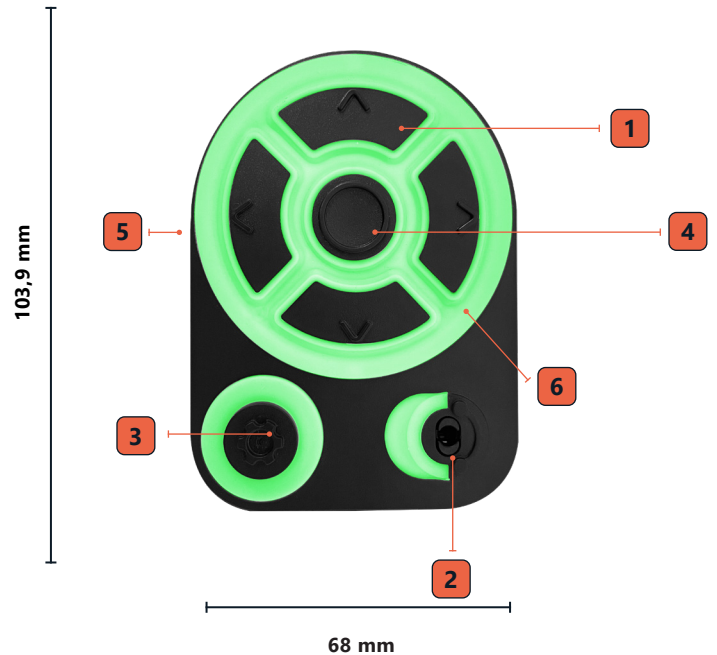

### Equipment

<b>1</b> Tactile arrow keys for navigate	<b>4</b> Tactile ENTER button to confirm/select
<b>2</b> Audiojack for headphones and microphone	<b>5</b> Dip switch on the rear for flexible installation; vertical or horizontal
<b>3</b> Tactile function button for opening menus	<b>6</b> RGB backlighting controllable in 3 zones



Exemplary color variants of the lighting

## ANKER EAA-Pad

Installation solutions



**EAA-Pad installation solution on the self-service terminal**

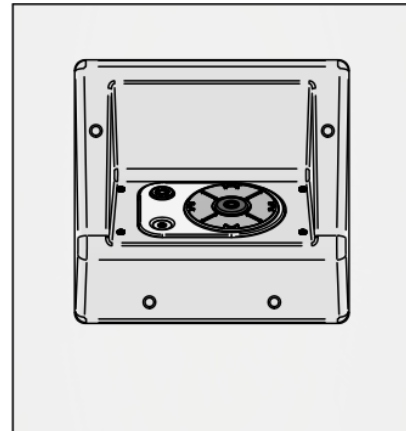

**EAA-Pad installation solution on the self-service terminal**

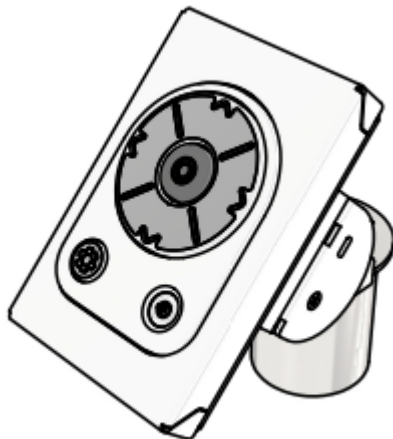

**EAA-Pad installation solution for poles**

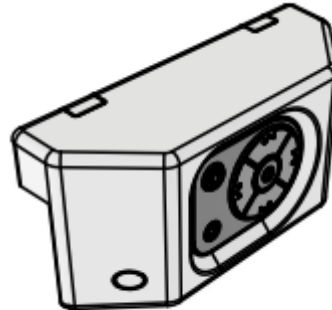

**EAA-Pad attachment/front mounting solution for e.g. scales**

### **Barrierefreiheitsstärkungsgesetz (BFSG) | European Accessibility Act (EAA)**

The Barrierefreiheitsstärkungsgesetz (BFSG) implements the requirements of the European Accessibility Act (EAA) in Germany and obliges companies to make digital products and services accessible. The aim is to enable equal access for people with disabilities.

