

# **User's Manual**

**2D Image Scan Engine**

## Revision History

Changes to the original manual are listed below:

Version	Date	Description of Version
1.0	2020/05/20	Initial release

# Important Notice

No warranty of any kind is made in regard to this material, including, but not limited to, implied warranties of merchantability or fitness for a particular purpose. We are not liable for any errors contained herein or incidental or consequential damages in connection with furnishing, performance or use of this material.

No part of this document may be reproduced, transmitted, stored in a retrieval system, transcribed, or translated into any language or computer language in any form or by any means electronic, mechanical, magnetic, optical, chemical, manual or otherwise, without express written consent and authorization.

We reserve the right to make changes in product design without reservation and without notification. The material in this guide is for information only and is subject to change without notice.

All trademarks mentioned herein, registered or otherwise, are the properties of their various respective owners.

Copyright © 2020. All rights reserved.

## **For CE-countries**

This scanner is in conformity with CE standards. Please note that an approved, CE-marked power supply unit should be used in order to maintain CE conformance.

## **Guidance for Printing**

1. This manual is in A5 size. Please double check your printer setting before printing it out.
2. When printing barcodes for programming, the use of a high-resolution laser printer is strongly suggested for the best scan result.

## **Table of Contents**

Important Notice .....	iii
Introduction.....	1
Overview .....	2
Components.....	2
Scanner Operation.....	3
Precautions .....	3
Maintaining the Scanner .....	3
ESD .....	3
Scan Angles .....	4
Scan Zone .....	5
Installation.....	6
FFC Cable.....	6
Z-5112 C & M Type Pin Definition .....	7
Mounting.....	9
Technical Specification .....	13

# Introduction

High scanning speed without compromising performance, the device is a powerful 2D image scan engine that easily decodes most 1D and 2D barcodes with intuitive aiming accuracy. It also supports standard serial, USB interface that can be easily integrated with most hardware platform. The compact dimension makes installation effortless even in the most space-constrained products, including mobile computers, kiosks, lottery machine and more. The device is the perfect solution for many industries.

- Ultra small size
- No separate decoder board required
- Flexible interface communications
- Outstanding 1D and 2D scanning performance
- Captures barcodes on mobile phone, tablet, or computer screens

# Overview

---

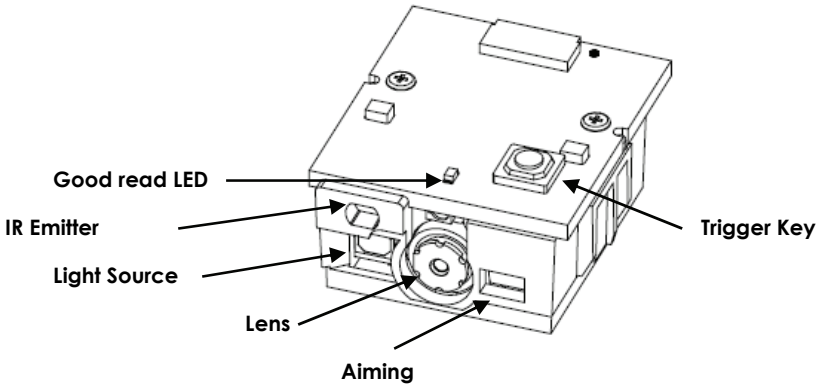

## Components

Description	Function
Light Source	Reinforced light brightness
Aiming	Produce easy to see scan line
Lens	Captures image for decoding
Trigger Key	Used to start a decode a session
Good read LED	Good read LED indicated
IR Emitter	Infrared emitter diode

# Scanner Operation

## Precautions

---

To ensure the scanner reaches its best performance, the following points need to be noticed when mounting the scanner:

- a. Do not place the scanner under direct sunlight or any other bright light source illuminating.
- b. When placing the barcode label, one must be careful not to over tilt, skew and/or pitch the barcode.
- c. Do not place the device at specula reflection position. The LED light of the scanner reflects directly back on the scanner if it is placed at specula reflection position. As to the nature of CMOS sensor, it will not be able to read any barcodes.
- d. The barcode label must be placed within the effective depth of field (D.O.F.) since it is the effective reading distance for the barcode from the scanner. For the best placing position, please refer to the Decode Depth of Field drawing.

## Maintaining the Scanner

---

Handling with care! The scan engines are electrostatic sensitive device; do not handle with bare hands. Store the engines away from dust and humidity places.



## ESD

The scan engines are protected from ESD events that may occur in an ESD-controlled environment. Always exercise care when handling the module. Use grounding wrist straps and handle in a properly grounded work area.

## Scan Angles

---

See the following illustrations for the effective barcode reading angles.

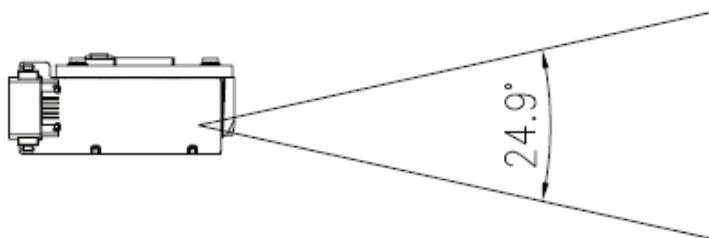
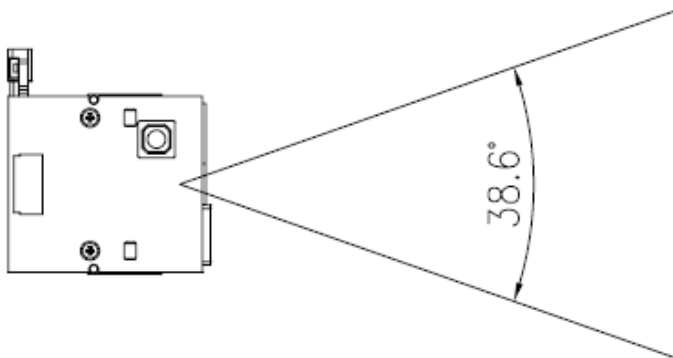



# Scan Zone

The effective reading distance for the scanner is illustrated as below.

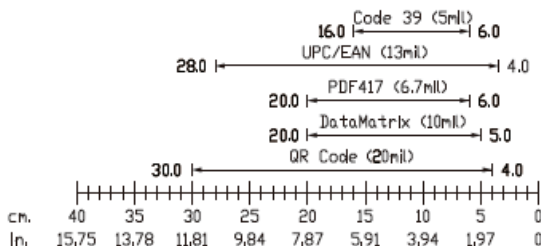
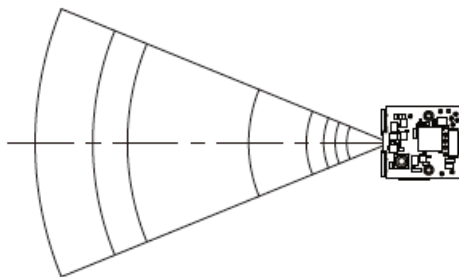
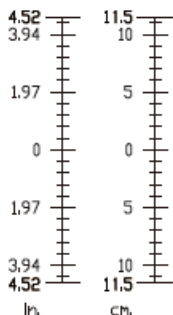

Different quality and density of a barcode could effect its decode depth of field. Usually when a barcode has poor printing quality or high density, the depth of field would be shorter. It is highly suggested **not** place the barcode label at the extremes of depth of field as it is often easy to move out from the reading range.

# Installation

## FFC Cable

A flex strip cable is needed to connect the scan engine to your host terminal, and different decode mode uses different FFC cable.

Decoded mode scan engine: 12Pin ZIF Pin configured FFC cable

The following figure shows the FFC cable dimension and its pin-out configuration.

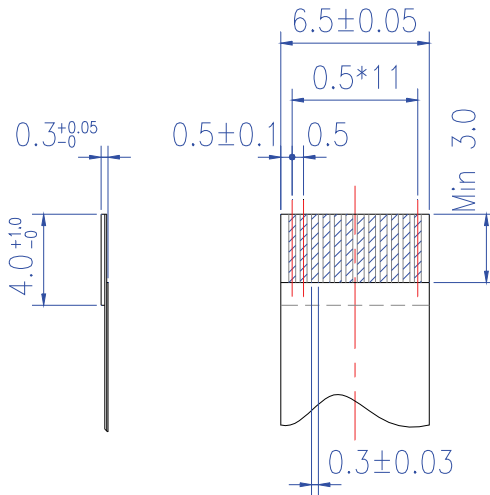

FFC Cable Dimension

## Z-5112 C & M Type Pin Definition

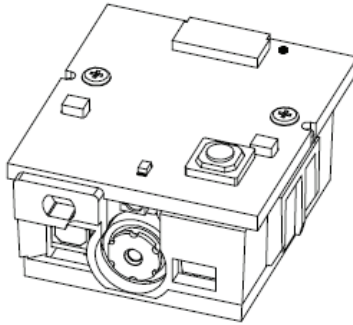

### Z-5112 C Type Pin Definition

PIN#	Signal Name	I/O	Function
1	V3.3	Power	3.0V~3.6V
2	RXD	I	UART receive data
3	Trigger	I	Trigger input L=enable
4	VBUS	Power	USB VBUS power
5	TXD	O	UART transmit data
6	RTS	O	UART request to send
7	GND	Power	Power supply ground
8	USB_DP	BI	USB_DP differential data signal
9	Good read	O	Good read LED output H=enable
10	CTS	I	UART clear to send signal
11	Beeper	O	Beeper output H=enable
12	USB_DM	BI	USB_DM differential data signal

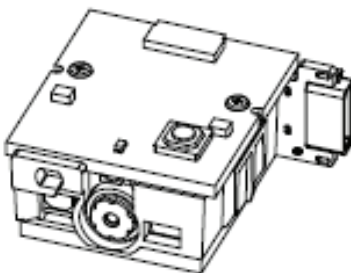

## Z-5112 MU Type Pin Definition

PIN#	Signal Name	I/O	Function
1	VBUS	Power	4.5V~5.5V
2	USB_DM	BI	USB_DM differential data signal
3	USB_DP	BI	USB_DP differential data signal
4	Trigger	I	Unused
5	GND	Power	Power supply ground

# Mounting

---

In this section, we will introduce ways to mount the scan engine into your design.

At the back of scan engine, there are two screw holes reserved for mounting, the scan engine can be fixed in any position and any angle without any degradation in performance. And to ensure the scanner reaches its best performance, the following points need to be followed when mounting the scanner:

To avoid direct sunlight or any other bright light source illuminating.

When placing the barcode label, one must be careful not to over tilt, skew and/or pitch the barcode.

To avoid putting the scanner in specula reflection position, the CMOS sensor will not sense the reading of any barcodes if the LED light reflects straight back.

The barcode must be placed within the effective depth of field (D.O.F.) area, the effective reading distance for the barcode from the scanner. Its theory is like a camera, if the object is placed within the focal range, and the image appears clearly. But if the object is outside the focal range, the image then is blurred. And different quality and density of barcodes could affect its D.O.F; usually a lower piece or high density of barcode, its depth of field is shorter. It is suggested to avoid using depth of field extremes range, barcode is easily moved away from the reading range.

For best placing position, please refer to the Decode Depth of Field drawing.

## Thermal Considerations

Electronic components in the Z-5112 will generate heat during the course of their operation. Operating the Z-5112 in continuous mode for an extended period may cause temperatures to rise on APU and decoder chip. Overheating can degrade image quality and affect scanning performance. Given that, the following precautions should be taken into consideration when integrating the Z-5112.

1. Reserve sufficient space for good air circulation in the design.
2. Avoid wrapping the Z-5112 with thermal insulation materials such as rubber.
3. Increase the thermal strategy to reduce the scanning engine continuous operating temperature.

### C Type Dimensions

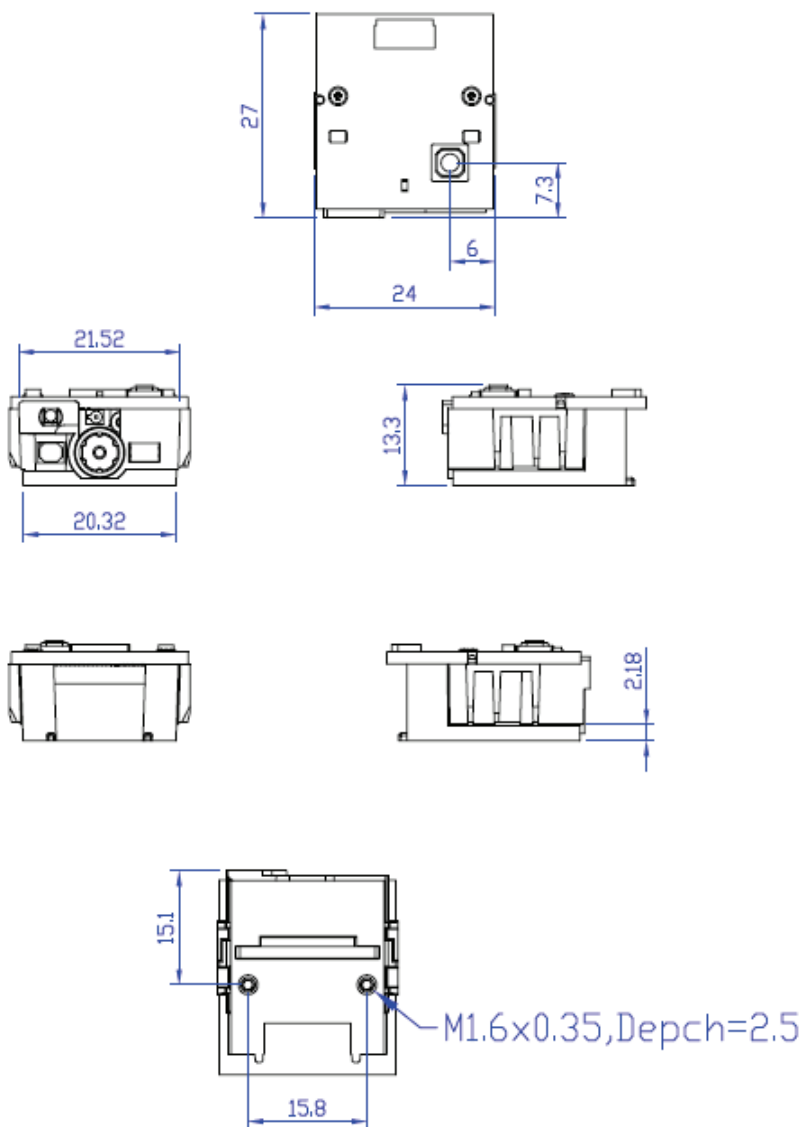

Outline Drawing

## M Type Dimensions

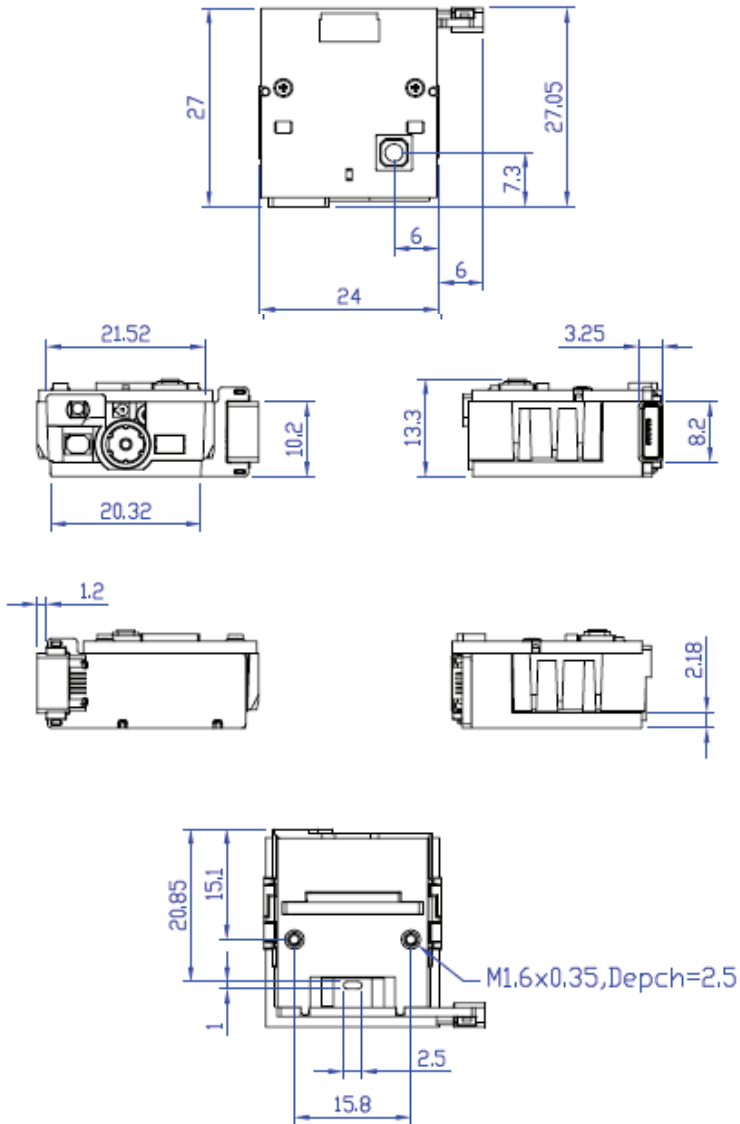

Outline Drawing

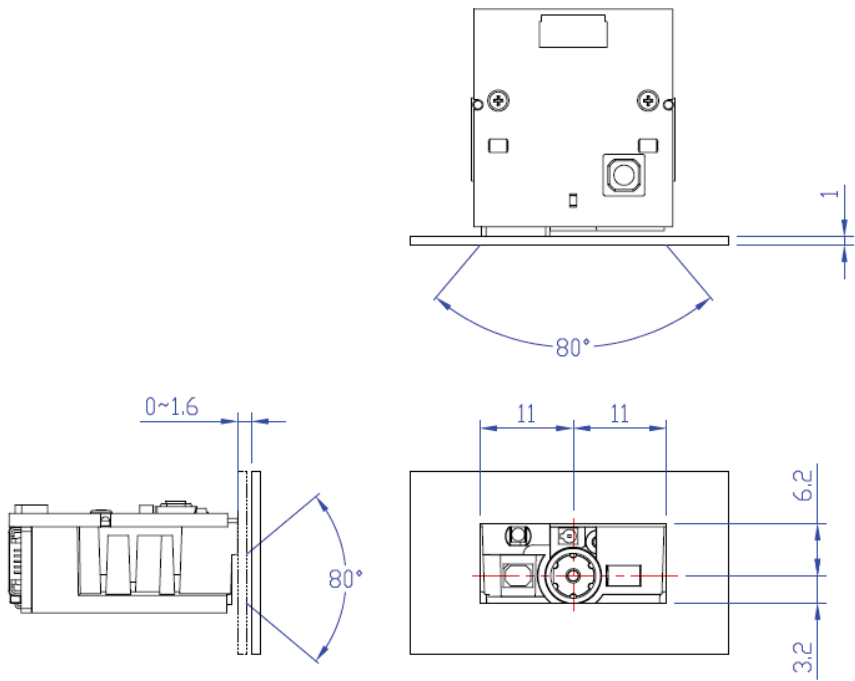

Cover Glass Drawing



# Technical Specification

Resolution	1280H x 720V pixels
Light Source	5000K LED (White)
Aiming Pattern	617nm LED (Red)
Image Field of View (Scan Zone)	38.6°H x 24.9°V
Roll/ Pitch/ Yaw (Skew)	360°/ ± 60/ ± 60°
Scan Rate	60 fps
Print Contrast Ratio (Minimum)	30%
Minimal Element Resolution	Code 39: 4mil PDF417: 6.7 mil Datamatrix: 7.5 mil QR Code: 7.5 mil