

Installation Guide

SPDS2104 + SPDS2119

Hook and rail VESA brackets (tilt)

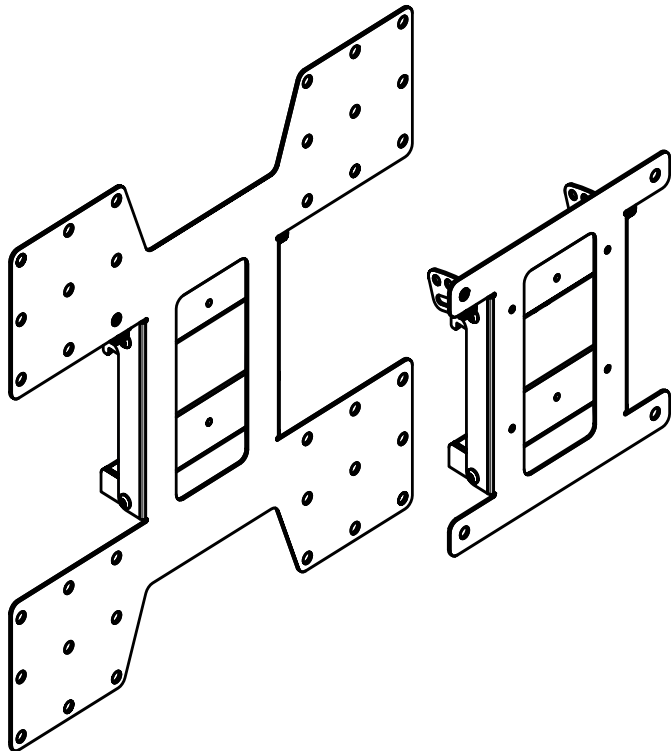



CAUTION

This product must be installed by a professional installer. It is recommended that more than one person is involved in the installation of this product.

Do not exceed the stated weight limits.

The maximum weight limit for this product is 150 kg per ceiling pole.

This product is intended for indoor use only.

If these installation instructions are not followed precisely, it could lead to product failure and potential personal injury.

Ergonomic Solutions cannot be held responsible for any failure or injury, if the installation instructions are not followed correctly.

Box content





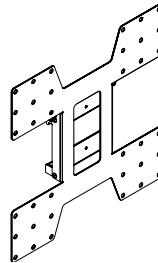
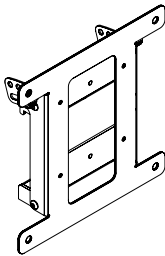

SPDS2104
VESA 200 w. tilt

or

SPDS2119
VESA 200/300/400 w. tilt



Fixings included in either config

-  **x4 M8 x 12mm screws**
-  **x4 M8 x 25mm screws**
-  **x4 M8 x 35mm screws**
-  **x4 M8 x 16mm screws**
-  **x4 M8 x 5mm spacers**
-  **x4 M8 washers**

A1 B1 Mount on screen

Step A2-A5: Rail mount
Step B2-B3: Pole mount

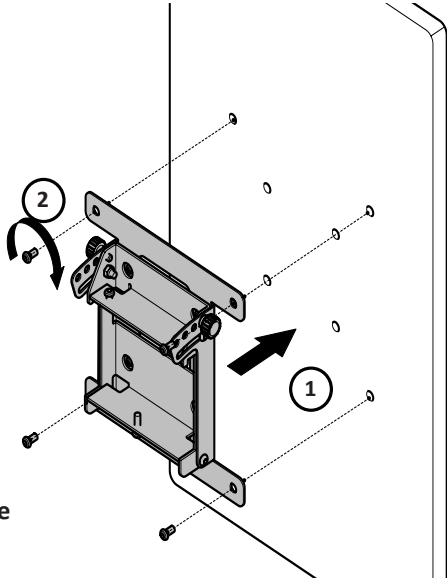

Choose the appropriate
VESA screw length

A2 Place on rail

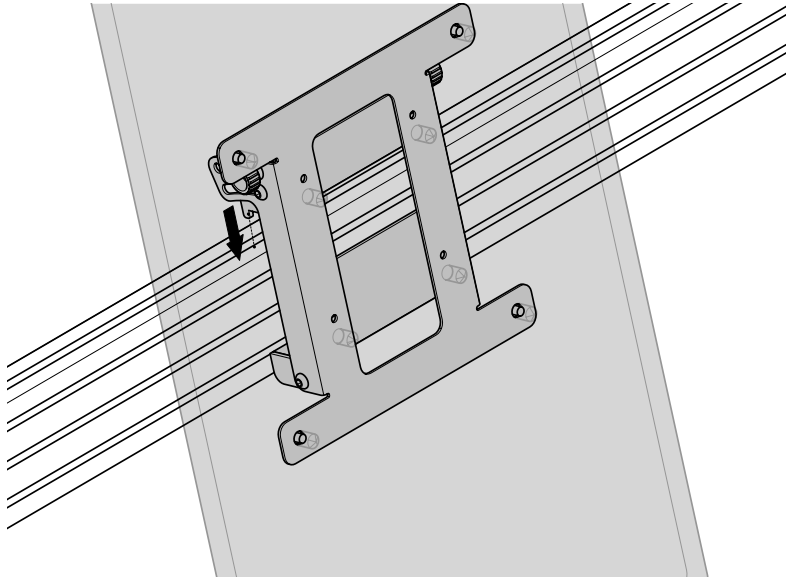

A3 – Fix on to rail

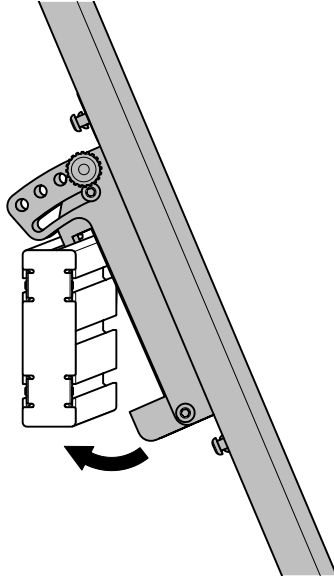

A4 – Level screen and secure with screw

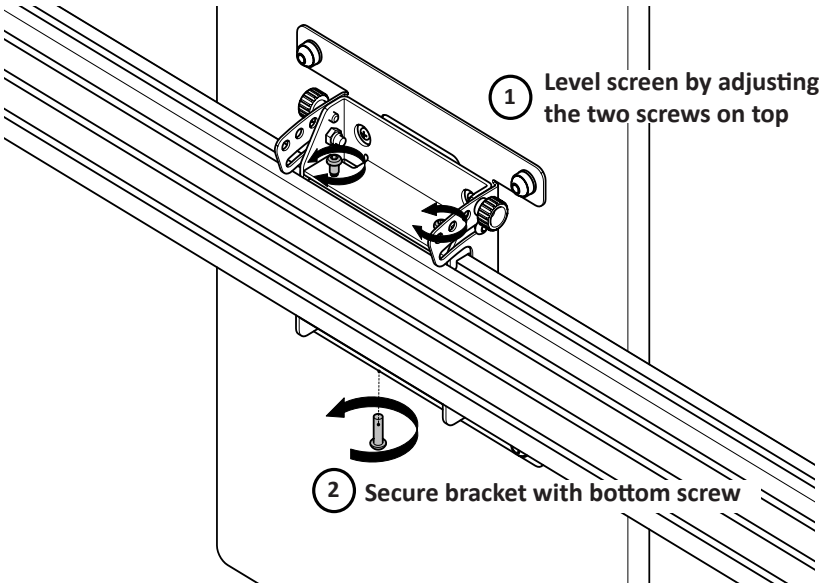

A5 For tilted screen

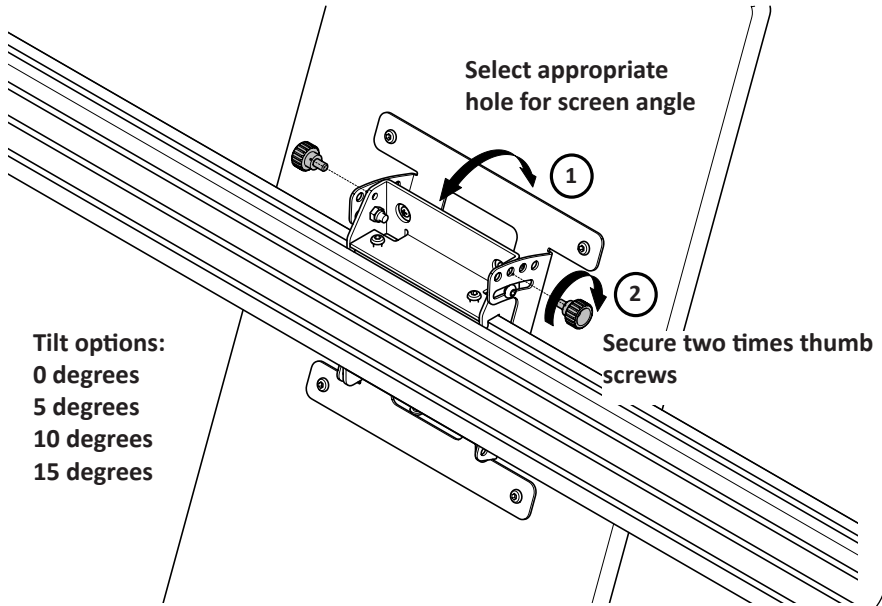

B2 Mount VESA adapter and screen on to the ceiling pole

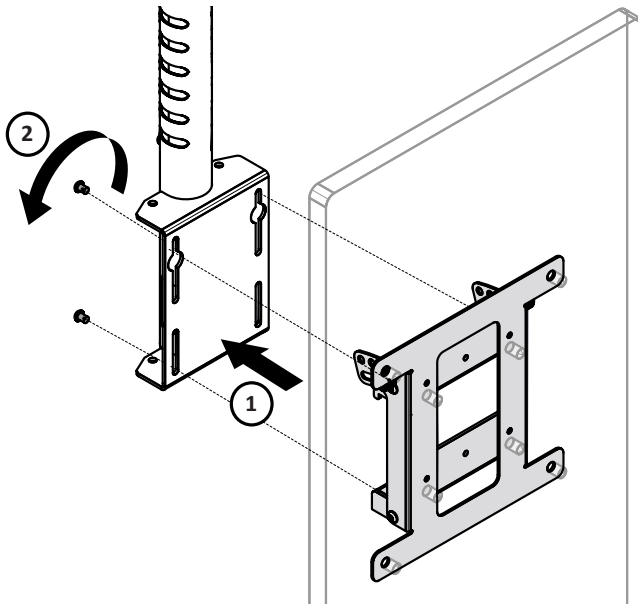

B3 For tilted screen

Tilt options:
0 degrees
5 degrees
10 degrees
15 degrees

